

# SMART BATTERY CHARGER

## OPERATING MANUAL



It is strongly recommended to read this manual completely before use! Damage resulting from misuse or modification will void your warranty.



**WARNING!** Charging lithium-based rechargeable batteries poses a risk of FIRE! NEVER treat lithium-based batteries in the same manner as other battery types. NEVER leave lithium batteries unattended while being charged! ALWAYS charge lithium-based batteries in a fireproof location! Failure to follow all care and handling instructions contained in this manual could result in quick, severe, permanent damage to the batteries and all surroundings!! Follow all safety precautions when using such batteries, as listed on page 3 of this manual!

---

## CONTENTS

Specifications and Features .....	2	Getting Started .....	4
Precautions .....	2	Battery Connections .....	5
Glossary of Terms .....	3	Starting Charge .....	5
Input Power .....	3	Charge Complete .....	6
Controls and Terms .....	3	Care and Handling of Batteries .....	6
Battery Types .....	4	Error Messages and Troubleshooting .....	7

# SPECIFICATIONS

---

AC Input:	100-240V AC 50/60Hz
DC Input:	11-15V DC, built in lead with alligator clips
Protective Devices:	Solid state reverse polarity and current overload
Case Size:	110×83×39mm
Weight:	230g

## SPECIFICATIONS FOR EACH OUTPUT:

Battery Types:	1-10S NiCd/NiMH 1-3S LiPo/LiFe/LiIon 6-12V Pb
Charge Rate:	0.1-4.5A
Charge power:	45W max.
Battery Capacity range:	100-9900mAh(6000mAh Default)
Fast Charge Termination:	Peak detection for NiCd/NiMH, CC/CV for Lithiums
Fast Charge Safety Timer:	180minutes(Default)
NiCd/NiMH Peak Sensitivity:	8mV for NiCd, 5mV for NiMH(Default)
Lithium Balancing Accuracy:	5mV per cell

# SPECIAL FEATURES

---

- \*With identical features and functions.
- \*A tiny built-in switching AC power supply is great for portability and cramped pit areas, yet can deliver up to 5.0 amps of charge current.
- \*A DC power lead with alligator clips easily connects to many 12V DC power sources.
- \*Easy to read LCD shows battery voltage, charge current, time and capacity-each output.
- \*A custom cc/cv algorithm carefully charges lithium-polymer, lithium-ion or lithium ferrite-phosphate(such as LiFeSource) batteries fully and safely!
- \*A precise peak detection system with automatic trickle charge fills NiCd/NiMH packs completely, for optimum battery voltage and run time.
- \*Push button controls and audible tones make for easy setup and control.
- \*Solid state reverse polarity and current overload protection ensure trouble-free operation.

# IMPORTANT PRECAUTIONS

---



- \*Do not leave the charger unattended while in use.
- \*Disconnect the battery and remove input power from the charger immediately if the charger or battery becomes hot!!
- \*Do not attempt to charge incompatible types of rechargeable batteries as permanent damage to the battery and charger could result.
- \*Do not use automotive type battery chargers to power the charger.
- \*Do not allow water, moisture or foreign objects into the charger.
- \*Do not attempt to use batteries with more cells or total voltage higher than listed in specifications.
- \*Do not overcharge batteries as permanent damage could result. Do not use a charge current rate which exceeds the safe level of the battery.
- \*Do not place the charger or battery on flammable surfaces or near combustible materials while in use, such as a carpet, cluttered workbench, paper, plastic, vinyl, leather, and wood, inside an R/C model or full sized automobile !
- \*Do not connect the charger to AC and DC inputs at the same time.
- \*Allow the charger and battery to cool down between charges.
- \*Always disconnect the charger from power source when not in use.

# CLOSSARY OF TERMS

**Amps(A):**The unit of measure for charge current.

**Milli-amps (mA):** A unit of measure current, being amps (A) multiplied by 1000 and listed as " mA ". So 2.5A is the same as 2500Ma (2.5 x 1000). Or, to convert mA to amps, divide the mA number by 1000. So 25mA is the same as 0.025A(25 divided by 1000).

**Capacity and milli-amp hours (mAh):**The amount of energy a battery can store is called its capacity, which is defined as how much current a battery can supply constantly over one hour of time. Most hobby batteries are rated for capacity in " mAh " or milli-amp hours. A 650mAh battery can deliver 650mA of current over one hour (650Ma x 1hr = 650mAh). A 3200mAh battery can deliver 3200mA(3.2A) of current over one hour (3200Ma x 1hr = 3200mAh),etc.

**" C " rating:** capacity is also referred to as the " C " rating. Some battery suppliers recommend charge currents based on the battery's " C " rating. A battery's " 1C " current is the same number as the battery's rated capacity number, but noted in mA or amps. A 600mAh battery has a 1C current value of 600mA, and a 3C current value of (3 x 600mA) 1800mA or 1.8A. The 1C current value for 3200mAh battery would be 3200mA (3.2A),etc.

## Input power

**AC Input:** For indoor use, this charger includes a built-in switching AC power supply that delivers power by connecting the AC power cord to a common 100-240V AC outlet.

**DC Input:** This charger can be powered by a portable 12V DC power source for use at the track. On the left side of the charger, connect the DC power cord's alligator clips directly to the output terminals on the 12V DC power source. Always match polarities (red lead to red " + " terminal, black lead to black " - " terminal). To utilize the charger's absolute maximum power capabilities the DC power source must be capable of delivering at least 5amps while maintaining 12 volts DC.



**WARNING!** Never accidentally short together the positive (+) and negative (-) Input connections when connected to 12V DC power. Failure to do so could result in permanent damage to power source and charger.

This charger is rated for a maximum output power of 45Watts output. Depending on certain conditions (if charge current is set to maximum, the maximum number of cells are connected to the output, and input voltage is low), the actual current delivered to the battery might be slightly lower than the setting. This is normal. The charger will be on at all times when connected to input power. Disconnect the charger from input power when not in use.

## CONTROLS AND CONNECTIONS



**TYPE STOP:**For selecting NiCd, NiMH, LiPo, LiFe and LiIon battery type, and the charge current rate. Also for manually stopping charge.

**INC Display:**For selecting different data to be viewed on the LCD.

Also INC Values

**DEC START:**For starting charge. Also DEC Values

Always connect the charger first. Then connect the battery to the charge lead. Always match polarities on the battery wires, charge leads and bannana jacks-black connections to black(-), red connections to red(+).

**BALANCE PORTS:**To connect 2S/3S lithium batteries.



# DETERMINING BATTERY TYPE AND SPECIFICATIONS

\* RATED VOLTAGE: If not printed on the battery's label, consult your battery supplier or determine the proper pack voltage as follows (refer to the charts on the right):

- a. NiMH and NiCd: number of cells  $\times$  1.20.
- b. LiPo batteries: number of cells  $\times$  3.70.
- c. LiIon batteries: number of cells  $\times$  3.60.
- d. LiFe batteries (Life Source): number of cells  $\times$  3.30.

LiPo, LiIon and LiFe Pack Voltages			
Number of Cells	Nominal Voltage		
	LiFe	LiIon	LiPo
1 cell	3.3V	3.6V	3.7V
2 cells	6.6V	7.2V	7.4V
3 cells	9.9V	10.8V	11.1V

## GETTING STARTED

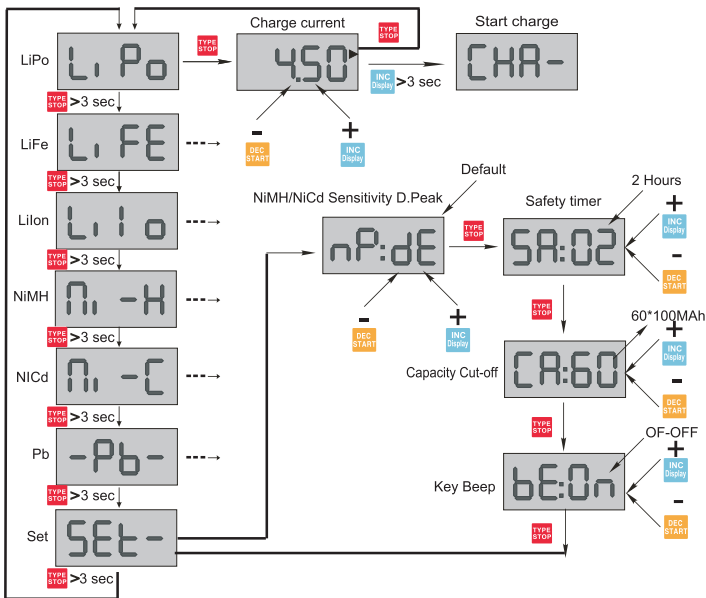

**WARNING! NEVER set the battery type to a type that does not match your battery! For example, accidentally charging a LiPo battery in the NiCd setting could result in an overcharge condition on the battery, which could result in an intense FIRE!**

## Charge current:

<b>NiCd/NiMH Charge Current Recommendations</b>	
Battery's Rated Capacity	Charge Current Setting
750-1000mAh	0.8A
1000-1400mAh	1.5A
1500-2400mAh	3.0A
2500-5000mAh	4.5A

<b>Lithium Charge Current Recommendations</b>	
Battery's Rated Capacity	Charge Current Setting
750-1200mAh	0.8A
1200-2200mAh	1.5A
2200-3500mAh	3.0A
3500-7500mAh	4.5A

## BATTERY CONNECTION

\*For NiCd/NiMH: Plug the adapter into the charger FIRST. Then connect the battery to the adapter ONLY after it has been connected to the charger. Proceed to the "Starting Charge" section.

\*For LiPo, Lilon OR LiFe: Lithium batteries for R/C are commonly available in two different assembly/wiring configurations: wired for balancing, and non-balanced. It's important to know which configuration you have before proceeding. Consult your battery supplier if you are unsure if your battery is wired for balancing, if it's not wired for balancing but has a built-in safety circuit, or neither.



**WARNING!** It is NOT recommended to charge a LiPo battery which is not wired for balancing, or which does not have a built-in protection circuit! Such types of LiPo batteries have NO means to protect the equipment or the user from damage that could result from an overcharge condition of any single cell in a pack.

**NON-BALANCED** packs are wired so the charger can only detect the voltage of the entire pack (not individual cells), so there is only one charge lead. It's highly recommended to ONLY use such types of LiPo packs if they have a built-in charge safety circuit which prevents a single cell in a pack from being overcharged. Simply connect the battery's main power lead to the charger's banana jacks (note proper polarity).

## STARTING CHARGE

\*Once the proper settings and connections have been made, the battery is ready to be charged.

\*To START CHARGE

\*During charge, the LCD will alternate between the battery voltage and charge current screens so you can quickly determine if charge is progressing correctly.

\*Pressing the Display button during charge will manually scroll the LCD through these screens.

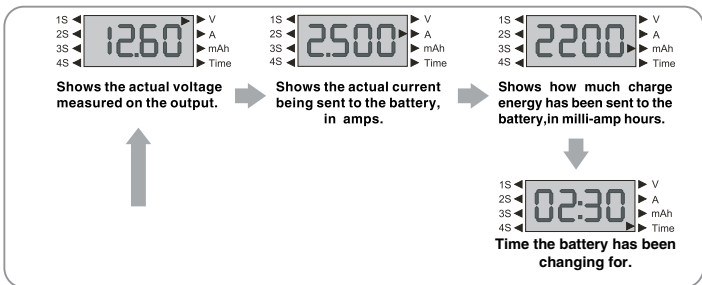

These screens are only shown for lithium based batteries.



Shows actual voltage of Cell 1 on lithium battery.



Shows actual voltage of Cell 2 on lithium battery.



Shows actual voltage of Cell 3 on lithium battery.



Shows actual voltage of lithium battery.



Shows actual voltage of Cell 4 on lithium battery.

Enter  > 3 s will Display

For NiCD and NiMH batteries, a linear charge current will be delivered to the battery. The peak detection method will be used to accurately look for the highest battery voltage during charge. Once this is detected, the charger will automatically stop fast charge and go to trickle charge mode.



**CAUTION:** Make sure the charge current setting is safe for your battery to prevent overheating of the cells. "AAA", "AA", "A", and "2/3A" size batteries generate heat more quickly than large sub-C batteries. Most radio batteries should NOT be charged at currents greater than 1.5A. Failure to follow this recommendation could permanently damage your battery.

Lithium batteries are charged using the "constant current/constant voltage" method (CC/CV). Constant current is delivered during the first part of fast charge. When the battery reaches a pre-set voltage, constant current is no longer delivered, and a constant voltage is applied to the battery. As the battery's voltage becomes equalized to the voltage on the charger's output, charge current will steadily begin to drop. This is normal. When current reaches an approximate value of 1/10C, the charge process will end completely.

## CHARGE COMPLETE

When the charger has determined the battery is full it will automatically stop charge and show "FULL" on the LCD. Audible tones will sound for about 10 seconds (pressing STOP while the tones are sounding will turn them off). Information regarding the finished charge can be recalled by pressing the "DISPLAY" button. Please refer to the flow chart on page 6 for the data that can be recalled.

For NiCd and NiMH batteries, the trickle charge current value is set automatically by the charger as shown in chart on the right, and shown in amps "A". The charger will remain in trickle charge mode until the battery is disconnected from the charger, or the STOP button is pressed again.

Trickle charge will NOT be applied to lithium batteries. When fast charge ends, lithium batteries can be disconnected from the charger and are ready for use.

If the fast charge 180-minute backup safety timer expires before the battery is fully charged, the display will show "STOP". If this occurs, you might want to attempt to re-charge the battery by starting another charge. Refer to the Trouble Shooting Guide for more details.

Trickle Charge	
Fast Charge Current Setting	Approximate Trickle Current
0.8A	0.05A(50mA)
1.5A	0.10A(100mA)
3.0A	0.15A(150mA)
4.5A	0.25A(250mA)

## CARE AND HANDLING OF NiMH BATTERIES

\*DO NOT allow batteries to overheat! Disconnected overheated batteries from the charger immediately and allow to cool.  
 \*DO NOT attempt to use the charger's lithium function with NiMH batteries.

\*Store NiMH packs with some voltage remaining on the cells (refer to battery supplier).

\*It is important to recharge NiMH batteries immediately prior to use, as they have a high self-discharge rate.

\* "AAA", "AA" and "A" size radio batteries can safely be peak charged at currents up to 1.5C to 2C (battery capacity x 1.5 or 2.0). High charge currents can overheat batteries and thus reduce service life, especially for smaller size cells.

## CARE AND HANDLING OF LiPo, Lilon, and LiFe BATTERIES



**WARNING!! DO NOT try to charge lithium-polymer (LiPo) or Lithium-Ion (Lilon) or LiFe cells in the same way as other battery types! Always read the instructions that are included with your lithium batteries carefully before use. Failure to follow these care and handling instructions can quickly result in severe, permanent damage to the batteries and their surroundings and even start a FIRE!**

- \* ALWAYS charge lithium batteries in a fireproof location, which could be a container made of metal or ceramic tile. Monitor the area with a smoke or fire alarm, and have a lithium approved fire extinguisher available at all times.
- \* NEVER attempt to extinguish a lithium fire with water or a non-lithium approved fire extinguisher! Use ONLY a "Class D" fire extinguisher.
- \* ALWAYS provide adequate ventilation around LiPo/Lilon/LiFe batteries during charge, while in use, and during storage.
- \* NEVER allow Lipo, Lilon or LiFe cells to overheat at any time, as they can and usually will become physically damaged and could possibly EXPLODE or catch FIRE!! If a battery becomes overheated (over 140F, 60C), disconnect it from the charge IMMEDIATELY!
- \* NEVER continue to charge LiPo, Lilon or LiFe batteries if the charger fails to recognize full charge. LiPo and LiFe cells which swell or emit smoke may be in an overcharge condition and should be disconnected from the charger immediately.
- \* NEVER set the charger's Lipo/ Lilon /LiFe battery voltage setting to a voltage that is HIGHER than the nominal rating of the battery itself, as such cells cannot handle overcharging in any way.
- \* NEVER charge LiPo, Lilon or LiFe batteries at currents greater than the maximum rated current as specified by the battery's manufacturer.
- \* NEVER allow LiPo cells to come in contact with moisture or water at any time.
- \* NEVER allow the internal electrolyte from LiPo, Lilon or LiFe batteries to get in the eyes or on skin-wash affected areas immediately if they come in contact with the electrolyte and contact your physician!
- \* NEVER attempt to use the charger's NiCd and NiMH functions for Lipo or Lilon batteries.
- \* ALWAYS keep lithium batteries away from children.

## ERROR MESSAGES AND TROUBLESHOOTING GUIDE

Several safety features are included in this charger to protect itself and the battery against certain unwanted conditions, As follows:

### LCD MESSAGE PROBLEM AND SOLUTION

- "Err.1" The DC input voltage is below 11.0V or exceeds 15V DC. Make sure the input voltage is within this range.
- "Err.2" A battery is not connected to the output. Make sure a good connection exists between the battery and charger and re-try.
- "Err.3" The battery is connected backwards to the output. Re-connect the battery to the charger's output with the proper polarity.
- "Err.4" The battery has become disconnected during charge. Re-establish a good physical connection between the battery and charger, and re-start charge.
- "Err.5" Some type of electronic interruption or malfunction has occurred. If you believe that some external force might have caused the charger to err, and that a true circuit malfunction has not occurred, you might attempt a re-start charge. Otherwise, if you believe the charger is not functioning properly, disconnect the battery from the charger, and the charger from the input power, and contact Hobby Services for further details.
- "Err.6" The charger has somehow fallen out of calibration.
- "Err.7" Li-xx Bat Low and Hi voltage error. When pack voltage of the connected lithium battery is not certain.
- "Err.8" Balance voltage error. When charging Li-xx with the balance cable connected to the charger, if balance cell voltage is higher or lower than acceptable voltage of each battery, this error should occur.
- "STOP" The 180-minute backup safety timer has expired. You can re-start charge or disconnect the battery from the charger.

**FULL** The battery is full.